

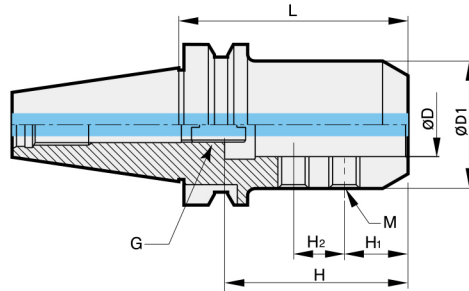

# BT-SLA

Side lock arbor\_사이드 락 아바



• 관련부품은 **117p** 를 참고하세요.

형번	ØD	L	ØD1	H	H1	H2	M	G	Kg	포장무게(Kg)	
BT30	BT30-SLA16-90	16	90	40	72	25	20	M10	M12	0.9	1.0
	BT30-SLA20-90	20	90	50	72	25	20	M12	M12	1.2	1.3
	BT30-SLA25-90	25	90	50	72	25	20	M12	M12	1.1	1.2
BT40	BT40-SLA16-90	16	90	40	72	25	20	M10	M12	1.4	1.6
	BT40-SLA20-90	20	90	50	72	25	20	M12	M12	1.8	2.0
	BT40-SLA25-90	25	90	50	72	25	20	M12	M12	1.6	1.8
	BT40-SLA32-90	32	90	60	82	25	25	M14	M12	1.8	2.0
	BT40-SLA32-105	32	105	60	82	25	25	M14	M12	2.0	2.3
BT50	BT40-SLA40-105	40	105	80	82	25	25	M16	M12	2.9	3.1
	BT50-SLA20-105	20	105	50	72	25	20	M12	M12	4.4	4.7
	BT50-SLA25-105	25	105	50	72	25	20	M12	M12	4.3	4.6
	BT50-SLA32-105	32	105	60	82	25	25	M14	M12	4.5	4.8
	BT50-SLA40-105	40	105	90	82	25	20	M16	M12	6.1	6.4
BT50-SLA42-105	42	105	90	82	25	25	M16	M12	5.9	6.2	

**C** 내부 쿨런트 시스템이 탑재되어 있습니다.



# HSK-SLA

Side lock arbor\_사이드 락 아바

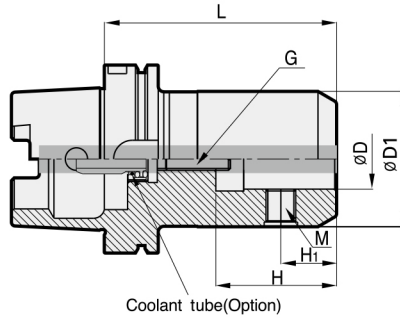

• 관련부품은 **117p** 를 참고하세요.

	형번	ØD	L	ØD1	H	H1	M	G	Kg	포장무게(Kg)
HSK63A	HSK63A-SLA20-100	20	100	52	51	25	M8	M12	1.6	1.8
	HSK63A-SLA25-105	25	105	65	59	25	M8	M12	2.1	2.4
	HSK63A-SLA32-105	32	105	72	63	30	M5	M12	2.3	2.6
HSK100A	HSK100A-SLA20-105	20	105	52	51	25	M16	M12	3.1	3.4
	HSK100A-SLA25-110	25	110	65	59	25	M18	M12	3.8	4.0
	HSK100A-SLA32-125	32	125	72	63	30	M20	M12	4.4	4.8

☐ 내부 쿨런트 시스템은 옵션 탑재 가능합니다.

## 별도구매

내부 쿨런트 시스템



## 상크별 구분

HSK50	HSK50A-CNS
HSK63	HSK63A-CNS
HSK100	HSK100A-CNS



# SK-SLA

Side lock arbor\_사이드 락 아바

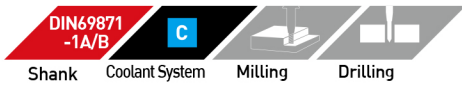

Fig.1

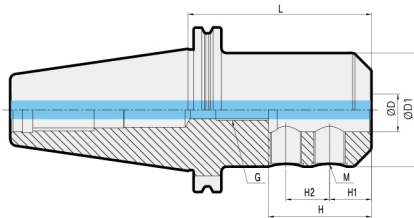
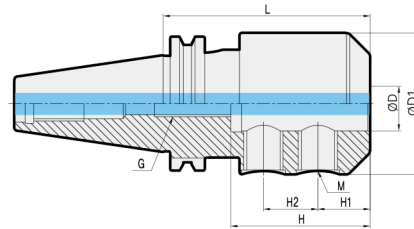

Fig.2



• 관련부품은 **117p** 를 참고하세요.

	형번	ØD	L	ØD1	H	H1	H2	M	G	Fig.	Kg	포장무게(Kg)
SK40	SK40-SLA16-75	16	75	48	49	24	-	M14	M12	-	1.4	1.6
	SK40-SLA20-75	20	75	52	51	25	-	M16	M12	-	1.5	1.7
	SK40-SLA25-95	25	95	65	59	24	25	M18	M12	2	2.1	2.4
	SK40-SLA32-105	32	105	72	63	24	28	M20	M12	2	2.8	2.9
SK50	SK50-SLA16-90	16	90	48	49	24	-	M14	M12	-	3.5	3.8
	SK50-SLA20-90	20	90	52	51	25	-	M16	M12	-	3.6	3.9
	SK50-SLA25-105	25	105	65	59	24	25	M18	M12	1	4.5	4.8
	SK50-SLA32-120	32	120	72	63	24	28	M20	M12	1	5.2	5.6
	SK50-SLA40-120	40	120	80	73	30	32	M20	M12	1	5.6	5.6

**C** 내부 쿨런트 시스템이 탑재되어 있습니다.



# SLA SPARE PART

사이드락 아바 관련 부품

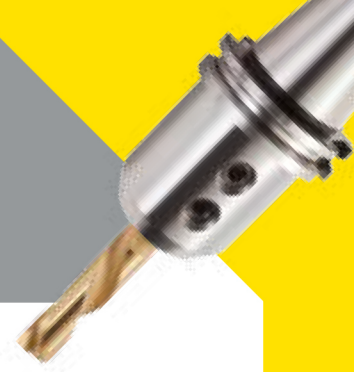

## 기본 구성품

Spare Part			
기본 구성품			
타입	세트 스크류		어드저스트 스크류
형번	이미지		
		BT type	HSK / SK type
SLA16		BTF1010	BTF1414 - 1.5
SLA20		BTF1212-1.5	BTF1616 - 1.5
SLA25		BTF1212-1.5	BTF1818 - 1.5
SLA32		BTF1414-1.5	BTF2020 - 1.5
SLA40		BTF1624-1.5	BTF2020 - 1.5
SLA42		BTF1624-1.5	BTF2020 - 1.5

※ HSK 타입은 어드저스트 스크류가 다를 수 있습니다.

## 별도 구매품

Spare Part			
별도 구매품			
타입	렌치		
형번	이미지		
		BT type	HSK / SK type
SLA16		LW - 5	LW - 6
SLA20		LW - 6	LW - 8
SLA25		LW - 6	LW - 8
SLA32		LW - 6	LW - 10
SLA40		LW - 8	LW - 10
SLA42		LW - 8	LW - 10